

# PACKAGE CONTENT

Wood  
 Original Chair  
 CCC100

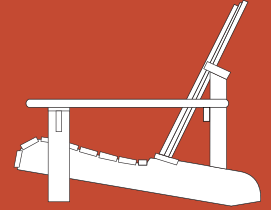

L1-7

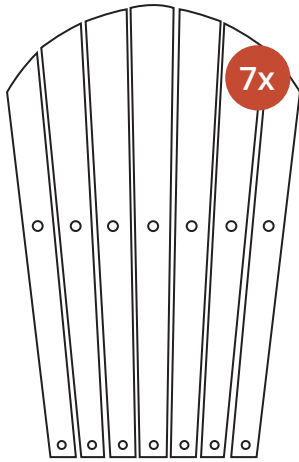

A

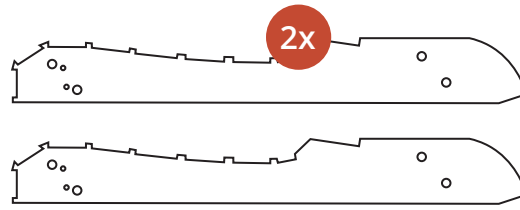

E

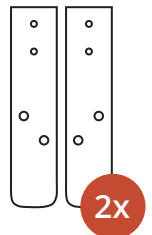

J

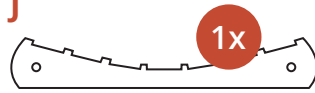

H

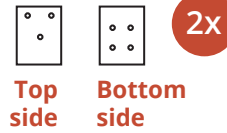

D

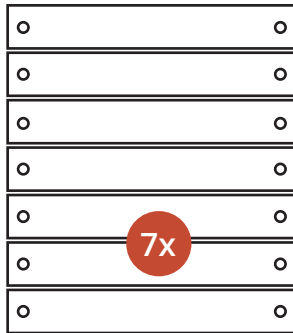

K

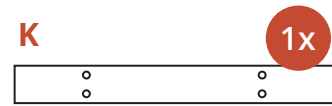

M



B

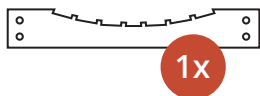

G



F

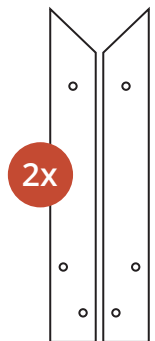

C

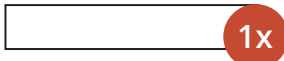

I

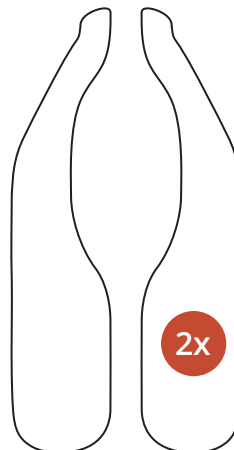

## MOUNTING HARDWARE



Watch the assembly video

[Watch video](#)

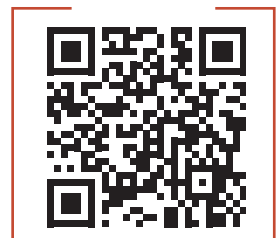

# ASSEMBLY INSTRUCTIONS

Wood  
Original Chair  
CCC100

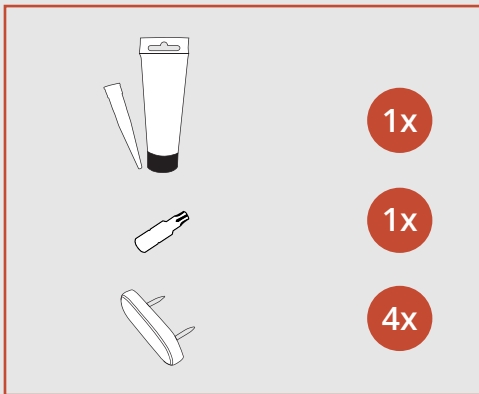
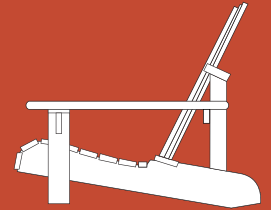

## Before you start

- Carefully unpack the package and check if all components are present.
- Required for assembly: cordless drill, hammer and an wrench 13. The bit for the drill machine is included in the bag of screws.
- For the CCC 100, all attachment points should be **glued** with the included wood construction glue for extra stability. One tube of glue is enough for three pieces of furniture.
- Due to the drying of the glue you can only coat the chair with oil after assembling it.

## Step 1 | Low back support

- Put the side pieces A with the curved sides up on a flat surface. Make sure the countersunk side of the pre-drilled holes face outward.
- Insert the low back support B into the last notch on the back of A, with the curved side facing forward and the countersunk sides of the pre-drilled holes facing up.
- Attach B to A with two 4x40 mm screws on each side.
- Attach plank C between the side pieces A with two 4x40 mm screws per side. Screw from the outside into the small countersunk holes.

## Step 2 | Seat slats

- Place the remaining slats D (without part M) in the notches on top of the side pieces A, with the countersunk holes facing up. Make sure the outer edges of the slats are aligned with the outer edges of A.
- Place the slat with the logo in the second notch.
- Secure the slats with a 4x40 mm screw on both sides.

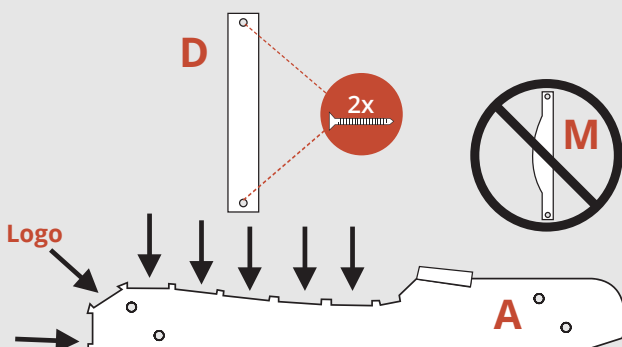
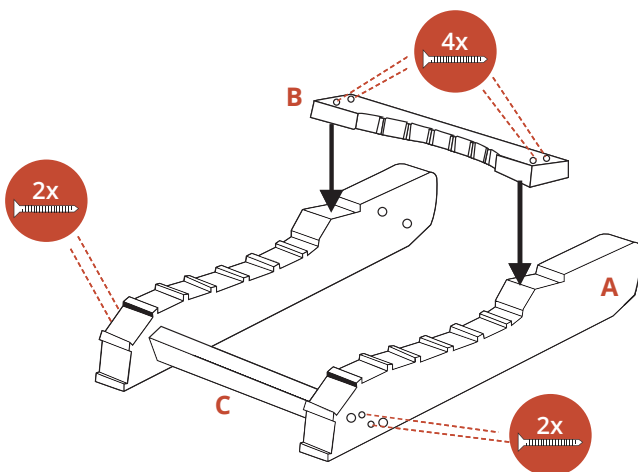

## ASSEMBLY INSTRUCTIONS

Wood  
Original Chair  
CCC100

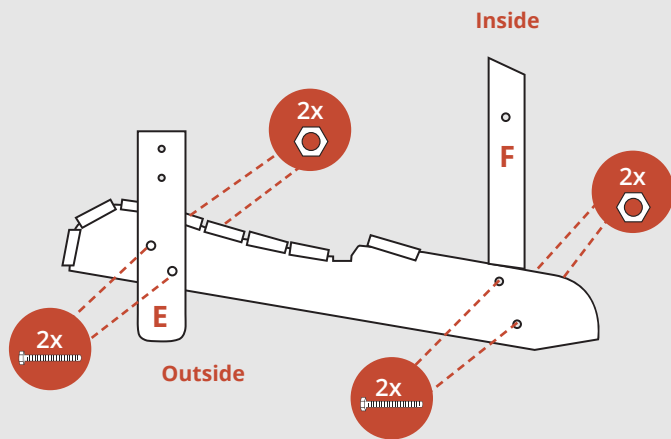
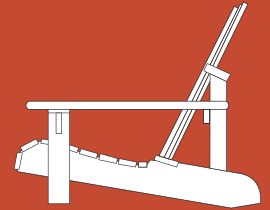

### Step 3 | Front chair legs and high back support

- Place chair leg E on the outside of side piece A, with the rounded side facing down and the countersunk holes facing in.
- Attach E to A by screwing two bolts + washers into the chair leg starting from the outside and securing them on the inside with a nut + washer.
- Place high back support F on the inside of side piece A, with the countersunk holes facing inward.
- Attach F by screwing two bolts + washers into the support starting from the outside and securing

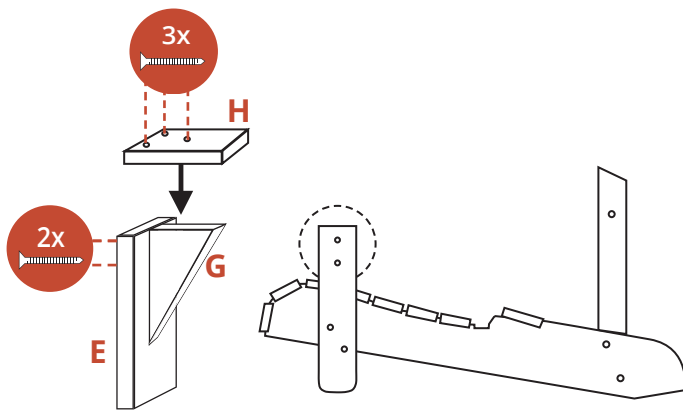

### Step 4 | Armrest holder

- Place triangle G on the outside of chair leg E. Center the triangle with the top side parallel to the top edge of the chair leg.
- Screw triangle G to E starting from the inside with two 4x40 mm screws. Place part H on top of the chair leg and triangle and secure with three 4x40 mm screws.
- Repeat these steps on the other side of the chair.

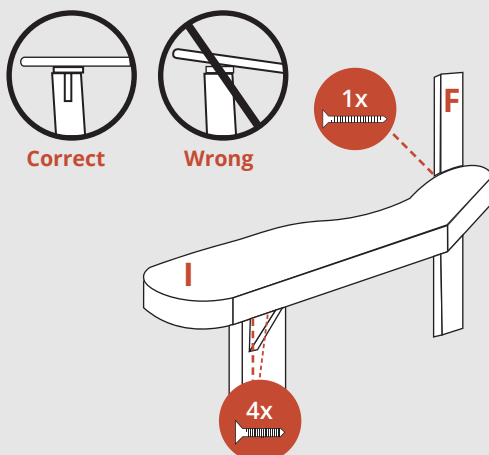

### Step 5 | Armrests

- Place armrest I on top of the just attached armrest holder H.
- Attach the backside of I to high back support F with a 4x40 mm screw. Screw from the inside of F. **Do not over-tighten.**
- Make sure the armrest lies flat on the carrier. If necessary, shift the chair leg until the carrier is parallel to the armrest.
- Take the smaller 4x30 mm screws; screw four of these through part (I) from underneath the armrest on each side.
- Completely tighten I at the rear.

## ASSEMBLY INSTRUCTIONS

Wood  
Original Chair  
CCC100

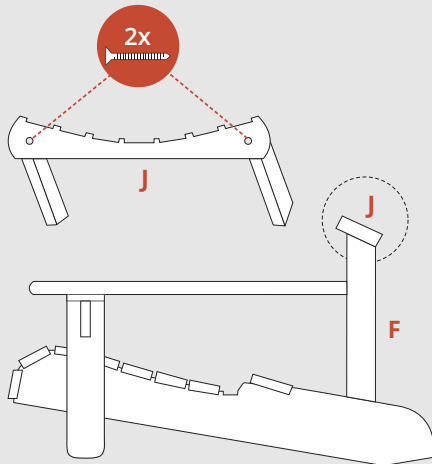
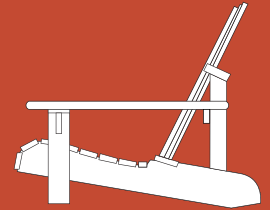

### Step 6 | High back support

- Place the high back support J on top of the planks F with the rounded side facing inwards and the countersunk holes facing up.
- Align J with the back edges of F. Make sure that the pre-drilled holes are centered on planks F.
- Attach J to F with a 4x40 screw on both sides.

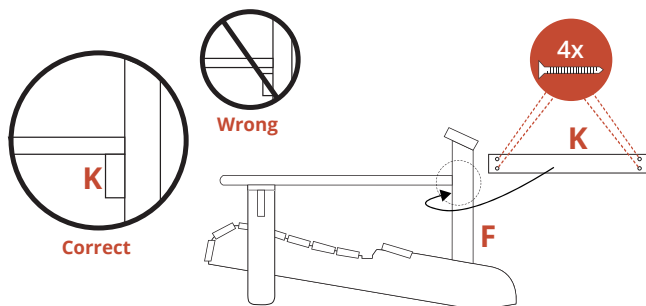

### Step 7 | Cross bar K

- Place cross bar K directly under the armrests against the planks F. Make sure the countersunk holes are visible.
- Screw K onto F with two 4x40 mm screws on both sides.
- Make sure K is securely attached.

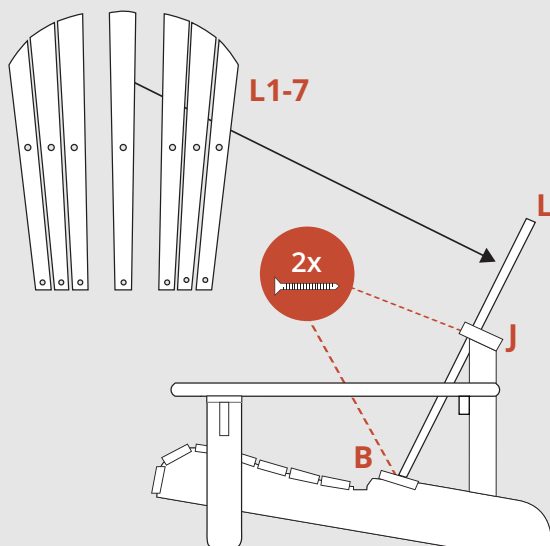

### Step 8 | Center back slat

- Lay down the back slats L1-7 in the correct order, starting with the longest slat in the middle. The slats should form an arch at the top.
- Place the center slat in the center notch from B and J with the countersunk holes facing forward.
- Make sure the slat fits exactly into the notch and is parallel to the bottom of the low back support B.
- Attach the longest, middle slat to B and then to J with a 4x40 mm screw.

## ASSEMBLY INSTRUCTIONS

Wood  
Original Chair  
CCC100

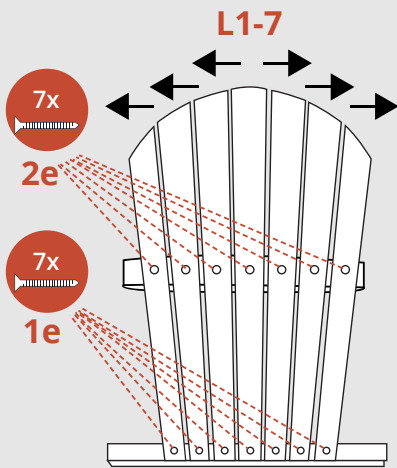
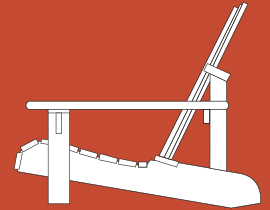

### Step 9 | Back slats

- Place the remaining back slats in their proper places.
- Fasten the slats at the bottom with 4x40 mm screws.
- Make sure that the slats are properly located at the top and form a nice arch. The distance between the slats should be even. Use the notches as reference points.
- Fasten the slats at the top with 4x40 mm screws.

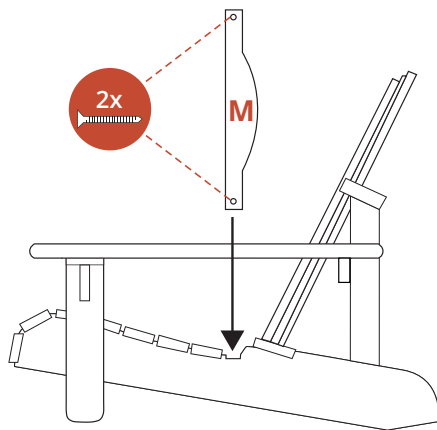

### Step 10 | slat M

- Insert slat M into the notches at the back of the seating, with the curved side facing back and the countersunk holes facing up.
- Attach M with a 4x40 mm screw on both sides.

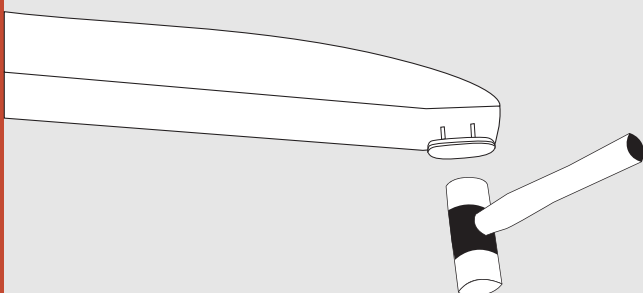

### Step 11 | Furniture gliders

Use a hammer to attach the 4 furniture gliders under the chair legs.

## ASSEMBLY INSTRUCTIONS

Wood  
Original Chair  
CCC100

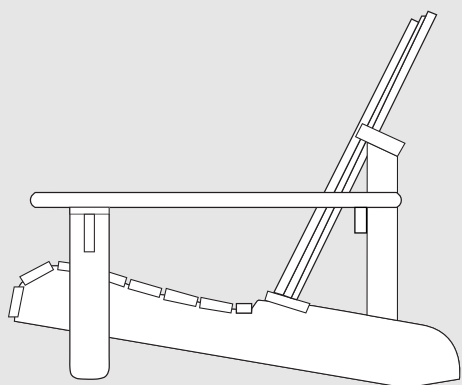
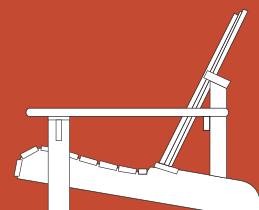

### Step 12 | Relax

After you're work is done, it's good to relax ... in your new Comfy Chair Original.

Enjoy!